

# Local Area Agreements – context and basics

Gill Leng

Director – Strategic Housing Services

HQN

hqn:

# Local government reform

- ; Aim: to deliver sustainable communities
- ; Strengthen local governance
- ; Enable community to have a greater say
  
- ; Relationships
- ; Partnership working
- ; Efficiencies
- ; Accountability

# How are sustainable communities delivered now?

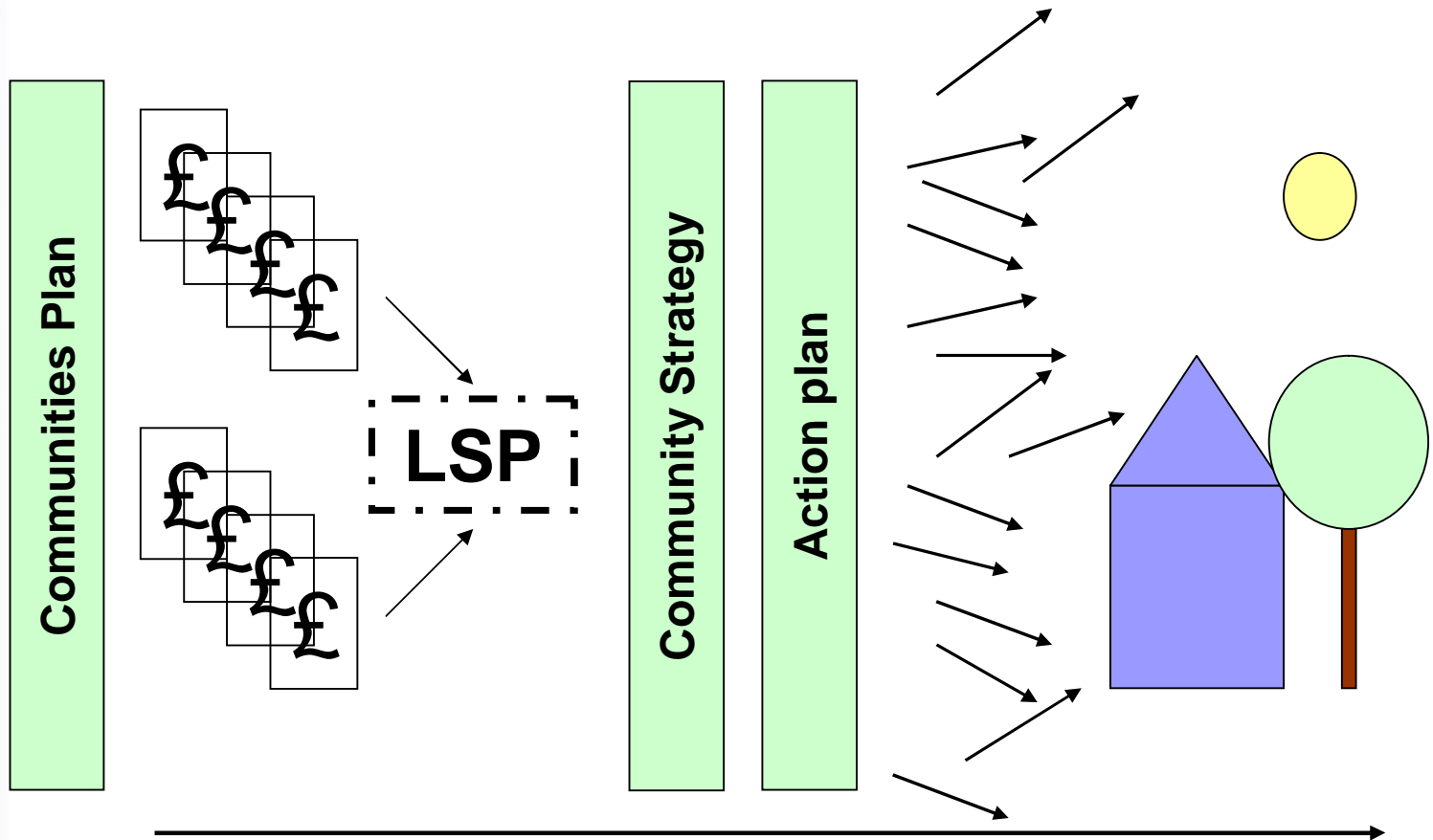

# How will sustainable communities be delivered in the future?

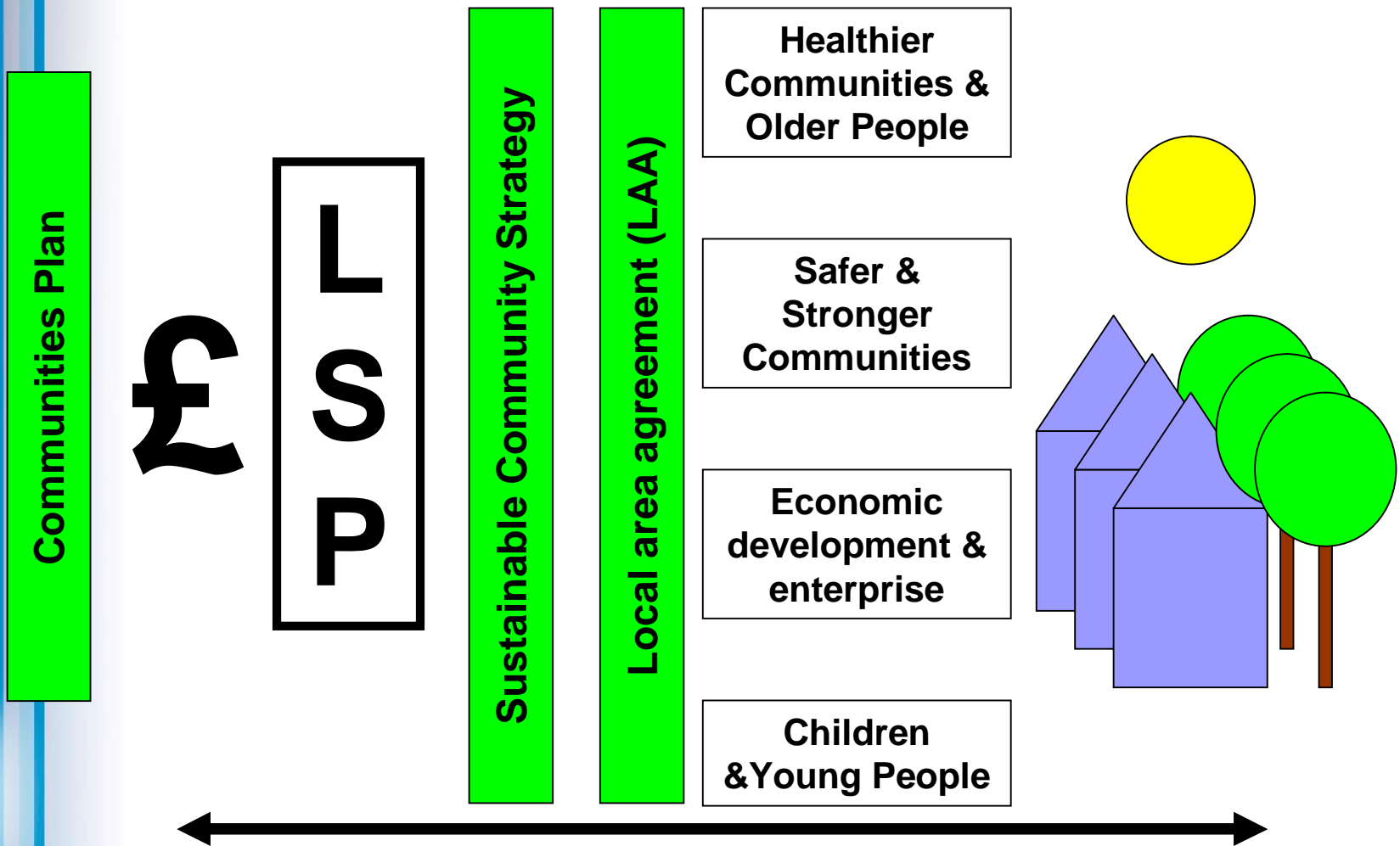

# What is a Local Area Agreement?

A targeted action plan to

- ; Deliver your local sustainable communities plan

AND

- ; Deliver national outcomes and targets
- ; Basis for the 'main conversation' between local strategic partnership and government

# Delivering private sector decency – what can it contribute?

- ;  
Investment and services to
  - ;  
Improve the condition of homes of vulnerable people
  - ;  
Enable independent living
  - ;  
Increase supply of housing
  - ;  
Renew and regenerate communities and markets
  - ;  
Improve thermal comfort and tackle climate change
  
- ;  
Mechanisms that enable
  - ;  
Community and neighbourhood involvement
  - ;  
Stakeholder networks
  - ;  
Knowledge of local and diverse need
  - ;  
Commissioning and procurement
  - ;  
Innovation and creativity in service delivery

# Timetable for developing and delivering the LAA

- ; All top tier authorities March 2007
- ; Annual refreshes and three-year review
- ; **Ongoing process**
- ; **Subject to assessment**
  - ; Comprehensive area assessments
  - ; National performance indicator framework

# Questions

- ; Added value?
- ; How do your existing plans link?
- ; What are your existing decision making structures?
- ; How will these link to the new arrangements?
- ; What will be the impact on services – commissioned or directly provided?
- ; How do you start to consider integration and value?
- ; What else do you need to know?

# Questions

## Contact details

- ; Gill Leng
- ; Email: [gill.leng@hqnetwork.co.uk](mailto:gill.leng@hqnetwork.co.uk)
- ; Tel: 07766 660799